

Add premium decorative effects to printed sheets



- Metallic foiling
- Holographic films
- Lamination

**THE MAGIC STARTS HERE**

 <b>10m</b> P/MIN	 <b>2,500</b> SRA4 P/HOUR	 <b>BURST</b> SEPARATOR WHEEL	 <b>100</b> ~ <b>400</b> gm <sup>2</sup>
 <b>FORMATS</b> Min: 210 x 297mm Max: 380 x 1219mm	 <b>MULTI</b> FX	 <b>INTEGRATED</b> COMPRESSOR	 <b>HOT</b> ROLLER





# Easily add decorative creativity to printed sheets with ColorFlare

Laminates | Foils | Holographics

- NEW Even more pneumatic pressure
- NEW Ships with premium finish flaring assembly\*
- NEW Level, +5° or +10° inclined delivery table
- NEW Lamination pull roll control
- Advanced dual process for lamination and foil flaring technologies for digital applications
- Multiple jobs and flaring effects are possible with just 1 machine
- No need to have traditional UV coating for diverse effects

The upgraded Intec ColorFlare is a compact and environmentally-friendly, dual laminator and foil-flaring device, designed to offer an in-house decorative effects solution for short-run, on demand digital applications, as well as lamination for traditional litho output too! With the ability to laminate and foil-flare straight out of the box, this high-quality production unit will soon start earning its keep, and *you*, a great reputation!

Intec ColorFlare: Raising ordinary print work to 'extra-ordinary'. ColorFlare has been developed to meet specific print-finishing requirements and built to exacting technical standards – with fully controllable pressure and heat processes, devised to deliver optimum results with today's digital print output.

Both lamination and flaring-film rolls are available in a choice of widths and lengths to deliver great value and cost-effective production – particularly when using the CF1200L model with its extended input table for banners and long media.

**A game-changing finishing device**  
**Faultless lamination.** Class-leading lamination for the commercial printer. Using state-of-the-art technology, combined with integrated pneumatic pressure, the Intec ColorFlare delivers superior bonding and faster production times – compared to standard systems. In addition, the fully-adjustable heat and pressure combinations enable a wider range of laminates to be used with printed media, including the traditionally troublesome digital print output!

**Stunning foil-flaring.** For today's printers who demand stunning results with that extra 'wow' factor – the ColorFlare delivers *more* than just class-leading lamination. Metallic, coloured, patterned or holographic



*Wedding invitation 2 x spot metallic foil flaring - Business card spot gloss lamination with metallic red foil flaring - Menu spot metallic foiling and holographic lamination*

style flaring foils can be added to digitally printed materials in either spot or flood treatments. This decorative effect is known as 'flaring', and traditionally, costly custom dies would be required to create these effects. However, ColorFlare can deliver instant and affordable results - and with upgraded pneumatic pressure, an even wider choice of media is now suitable for great results! Even further-advanced effects can be delivered by combining Intec special corona-treated laminates with Intec decorative effect flaring foils. Clever compound treatments deliver ultra-premium results - all from one compact device!

**Unique differences**  
**Visual and tactile decoration.** Intec has a range of specially formulated digital laminates, each featuring an advanced corona treatment,

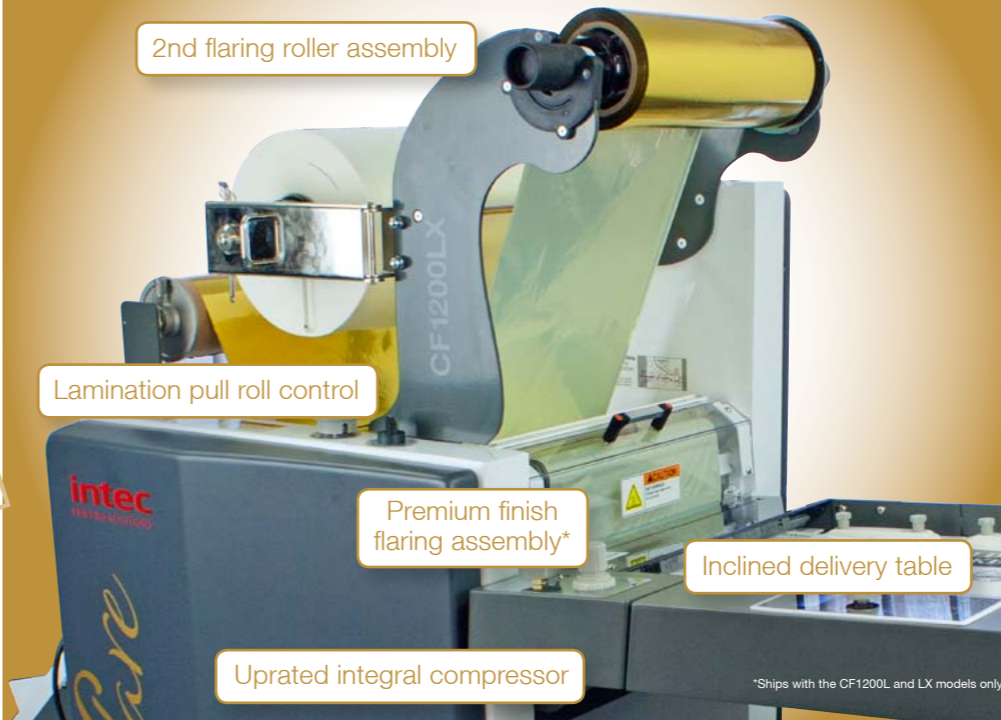

## Maximise output with the flagship CF1200LX

**2nd flaring roller assembly**  
 This additional arm and roller assembly allows both laminates and metallic foils to be loaded simultaneously - reducing set up times and enabling a much faster switch between media. Furthermore, this unique additional flaring roller assembly, enables dual - even multiple - metallic rolls, to be loaded for foiling of multiple metallics - all at the same time!

**Premium finish flaring assembly**  
 This 'accessory' now ships as standard with the CF1200L and LX models and is easily installed within moments. It is utilised when a superior mirror finish is desired foil. The super-soft surface of the roller gently smooths the foil into a perfectly flat condition, just at the point of application.



Metallic spot foil flaring - choice of finishes - makes your print ooze premium quality



Create the 'WOW' effect with high gloss lamination to make your print 'sing'



Carbon fibre holographic lamination adds a touch of mechanical techno-class

which enables *subsequent overprinting* through digital devices. This provides the opportunity to further enhance printed materials with additional decorative effects when using a combination of lamination and foil flaring. No ordinary laminating device can achieve *anything like* these unique and superb results!

**Speedy and accurate production**  
 Turnaround times and waste are further minimised with the ColorFlare unique 'burst separation' system. The laminating film is micro-perforated on the edge by the robust marking device and then separated by the pneumatic burst roller. This easily separates the laminated sheets prior to the actual edge of the media, leaving clean and square datum edges from which to measure, cut, fold or guillotine. Other devices tend to need time-consuming and untrue manual separation.

**Premium effects gain premium profits**  
 The flexibility to create and control stunning effects from just one compact device will lift ordinary print work to the level of extra-ordinary – and offers an even greater return on investment.



Set level, 5° or 10° inclination  
 The new inclined feed table can be set level, or at 5° or 10° to aid semi-automatic feeding, which helps to increase productivity



The new pull roll control, enables improved foil flaring results by allowing the user to disengage the lamination pull roller when performing foil flaring



Easy-to-use touch panel provides instant digital control, including sheet size, speed and temperature for laminates and flaring / decorative effect films



Premium finish flaring assembly helps achieve a superior mirror finish when foil flaring large areas. Now comes as standard with CF1200L and LX models



Even more pneumatic pressure with CF1200 models, offering wider choice of media for stunning metallic foil flaring results



Automatic burst separating system separates sheets and delivers a clean datum edge from which to easily cut or guillotine

colorflare  
 Premium decorative effects for digital solutions





ColorFlare printer compatibility guide\*



Intec ColorFlare has been developed to work with the Intec ColorSplash series and is compatible with the world's top digital printer manufacturers



\*Call for confirmation of model compatibility

Technical specifications*		
Laminating speed	1.5m/min ~ 10m/min	
Base substrate thickness	100 ~ 400gm <sup>2</sup>	
Front roller diameter	Top: high glossy chrome 100mm Bottom: silicon 80mm	
Rear roller diameter	Silicon 55mm	
Power requirement	AC 220~240V, 50/60Hz, 12A	
Power consumption	2.8kw	
Warm-up time	5 minutes	
Heating system	Infrared heater	
Laminating temperature	Maximum 150°C	
Temperature control	Capacitive touch screen	
Speed control	Capacitive touch screen	
Display system	LCD Panel	
Roller pressure	Pneumatic cylinder	
Film core size	77mm (3") / Dual - 58mm, 50mm	
Air compressor	100 psi maximum pressure, 3.2 CFM open flow (50 Hz)	
Temperature sensing method	Thermo-couple inserted in the roller shell	
Net weight	187kg	
Dimensions		
Model	W x L x H	
Paper size	Maximum - Minimum	
CF1200	710 x 1650 x 1350mm	380 x 500mm - 180 x 210mm
CF1200L	710 x 2010 x 1350mm	380 x 1219mm - 180 x 210mm
CF1200LX	710 x 2010 x 1475mm	380 x 1219mm - 180 x 210mm

ColorFlare footprint

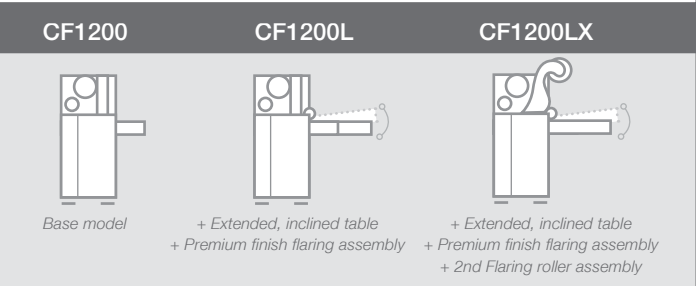
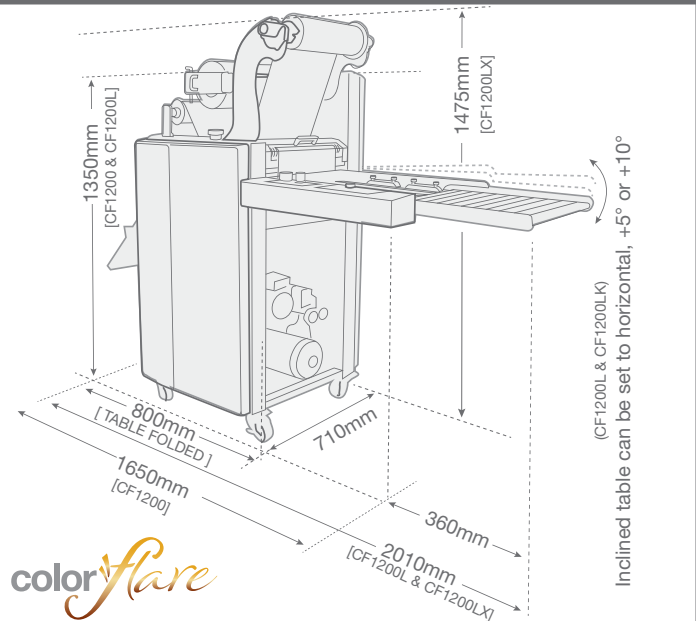

**A growing range of consumables...\***

**Lamination films**  
Various finishes including: gloss, matt and soft touch, for litho and digital print. Digital laminates are corona-treated for subsequent over-printing.

**Foil flaring films**  
Available in a growing range of colours including: gold, silver, red, green, blue, violet, black, white and clear gloss. All can be applied direct to print.

**Holographic flaring films**  
Such as: sparkle, milky way, crystal, carbon fibre... Perfect for adding premium effects to print.

\*See consumables support sheet.

